

LIVE ANIMAL REGULATIONS

The following information is provided to clarify any questions you may have regarding the LIVE ANIMAL ACCEPTANCE CHECKLIST. It is very important that the live animal you are accepting meets all the criteria on this checklist. For additional information regarding live animal acceptance and handling, refer to the IATA Live Animal Regulations. You can also find this information in 9 CFR, Subchapter A – Animal Welfare or on the Internet at <http://www.aphis.usda.gov/ac>. Since failure to comply with any of these regulations will result in Continental Airlines being fined, we will not make exceptions to these regulations. We will however attempt to assist the customer in correcting any non-compliance items. Customers in the U.S. who have questions regarding these regulations may contact the USDA Voice Response Service at 800-545-USDA (8732) or through the Internet site shown above. The USDA Voice Response Service can also be used to determine individual state regulations.

Kennel Sizing Chart for Dogs and Cats

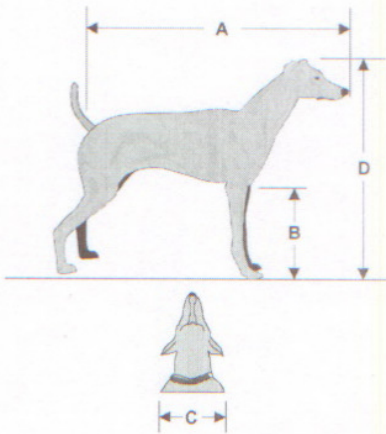

A = Length of animal from nose to root of tail.
 B = Height from ground to elbow joint.
 C = Width across shoulders.
 D = Height of animal in a natural standing position from the top of the head or the ear tip, whichever is higher.

For dogs or cats traveling **international** or short nosed dogs determine the kennel size by:

$$\begin{aligned} \text{Length} &= A + B \\ \text{Width} &= C + 1\text{in (3cm)} \times 2 \\ \text{Height} &= D + 3\text{in (7cm)} \end{aligned}$$

For all other dogs and cats, use:

$$\begin{aligned} \text{Length} &= A + \frac{1}{2} B \\ \text{Width} &= C \times 2 \\ \text{Height} &= D \end{aligned}$$

For kennels containing 2 dogs or cats, use the size of the largest animal to determine kennel size. The length and height are determined the same as for a single animal and multiply $C + 1\text{in (3cm)} \times 3$ or $C \times 3$ respectively to determine the width.

See the diagrams below:

International Dogs and Cats or Short Nosed Dogs

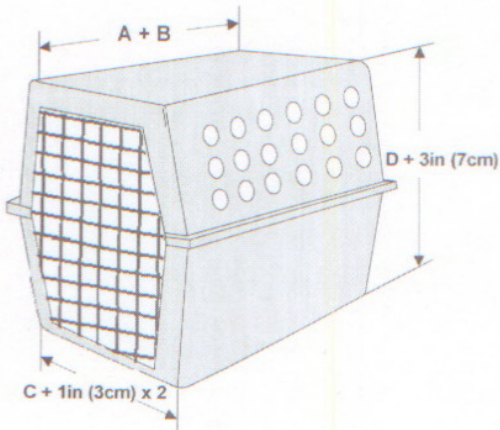

Domestic Dogs and Cats

